



THE WORLDWIDE LEADER IN VIBRATION TECHNOLOGY

ENTREGA INMEDIATA



2 AÑOS DE GARANTÍA



5 AÑOS DE GARANTÍA



ENTREGA INMEDIATA



MOTOVIBRADORES

MVE Estándar

Solución eficiente, entrega inmediata

Para el Transporte, cribado, alimentación y descarga de tolvas.

Sectores: Alimentario, construcción, minería y fundición.

Desde 0.04 hasta 13,9 kW (2-4-6-8 polos)



MVE- Exe Seguridad Incrementada

Seguridad en ambientes peligrosos

Cribado, alimentación, vaciado de tolva.

Sectores: alimentación, minería, química.

De 0,16 a 7,6 kW (2-4-6-8 polos).



MVE-Exd Antideflagrante

Seguridad en ambientes extremadamente explosivos

Cribado, transporte, alimentación.

Sectores: petróleo y gas, minería.

De 0,35 a 3,6 kW (2-4-6-8 polos)



MVE-Micro

Cuerpo sellado de una única pieza

Tolva de vaciado, compactación.

Sectores: alimentario, plásticos, químicos.

De 0,03 a 0,07 kW (2 polos), 1Ph, 3Ph



OWC Suspensiones Oscilantes

Suspensiones elásticas para equipos vibrantes

Aplicaciones: cribas vibrantes, alimentadores, escurridores,

mesas de compactación y máquinas vibrantes.

Sectores: canteras, minería, plástico, químico, reciclaje, procesamiento de alimentos.

Desde 5 kg hasta 1.600 kg de capacidad de carga.



MVE-SS Acero Inoxidable

Específico para aplicaciones de procesamiento de alimentos

Alimentación, transporte, cribado, clasificación.

Sector: procesamiento de alimentos.

De 0,12 a 0,77 kW (4-6-8 polos).



MVE-FD Flanged Drive

Diseñado para cribas vibrantes horizontales e inclinadas

Máquinas vibrantes y equipos para agregados, procesamiento de tierra y minerales.

Sectores: cantera, minería.

De 2,5 a 8 kW (6-8 polos).



MVE-F Brida

La mejor solución para máquinas vibrantes circulares

Desbarbado, pulido, abrillantado, secado.

Sectores: cerámica y todos los demás sectores industriales.

De 0,3 a 2,5 kW (2-4-6 polos).

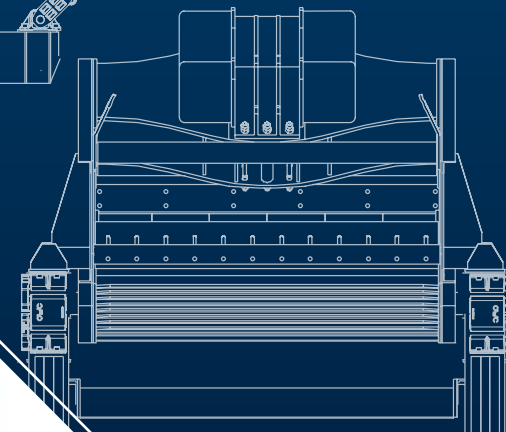
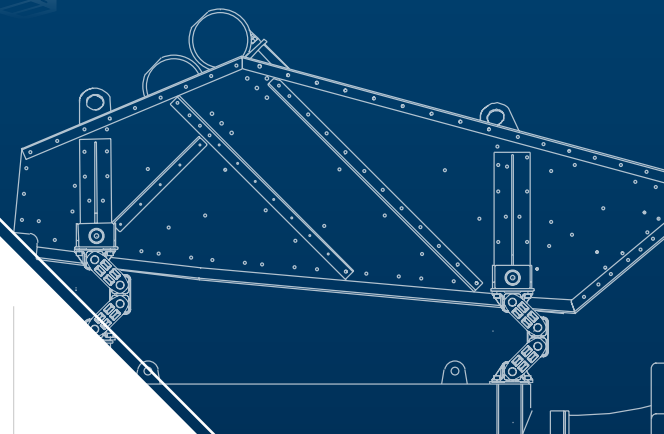

MVE-DC Corriente Continua

Protección IP 66.

resistente a choques accidentales

Ideal para bombas de hormigón.

De 0.08 a 0.16 kW, 12V y 24V.



MVE-SV Vibrador Largo

Diseñado para ser instalado sin ninguna viga de apoyo

Aplicaciones de cribado

Sectores: cantera, minería, petróleo.

De 2,2 a 3,8 kW (4 polos).



WWW.OLIVIBRA.COM

FCOES 04/23 rev 6.1

Electric Motovibrators SVE Range





SVE RANGE OVERVIEW

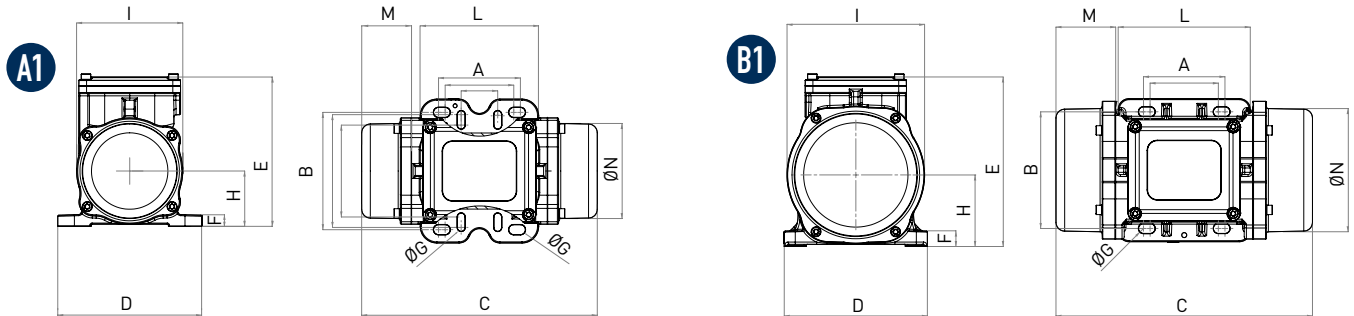

2 POLES – 3000/3600 rpm

Model	Centrifugal Force		Weight	ELECTRICAL SPECIFICATIONS			
	(kg)	(kN)	(kg)	Output Power	Nominal Current	Ia/In	Cable Gland
				(kW)	A max. (Y)	50Hz	
SVE 60/3N-10A0	66	0.65	4.2	0.09	0.25	3.2	M16
SVE 100/3N-10A0	98	1	5	0.09	0.25	3.2	M16
SVE 200/3N-20AM	198	2	6.7	0.09	0.35	3.5	M20x1.5
SVE 300/3N-30AM	311	3	10.3	0.16	0.52	3.8	M20x1.5
SVE 400/3N-30AM	400	4	11.1	0.20	0.58	3.7	M20x1.5
SVE 500/3N-40AM	516	5	16	0.37	0.96	4.2	M20x1.5
SVE 700/3N-40AM	750	7	16.8	0.45	1.25	4.5	M20x1.5
SVE 800/3N-51AM	788	8	20.8	0.55	1.45	4.0	M20x1.5
SVE 1200/3N-51AM	1,018	10	22.5	0.75	1.85	4.6	M20x1.5
SVE 1300/3N-51AM	1,386	13	24.6	1.10	2.44	5.4	M20x1.5

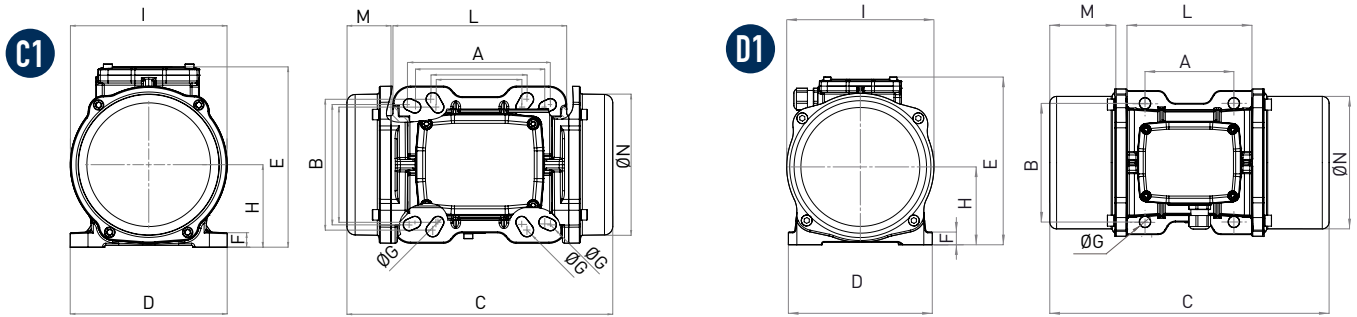

Model	Drawing	Size	DIMENSIONAL SPECIFICATIONS (mm)												
			C	M	A	B	Ø G	Holes	D	E	F	H	I	L	N
								n°							
SVE 60/3N-10A0	A1	10A0	221	48	Multiple Footprint 62-74 106 9 33 83-102 7			4	149	152	14	65	125	125	108
SVE 100/3N-10A0	A1	10A0	221	48	Multiple Footprint 62-74 106 9 33 83-102 7			4	149	152	14	65	125	125	108
SVE 200/3N-20AM	A	20AM	221	48	Multiple Footprint 62-74 106 9 70 130 9			4	149	152	14	65	125	125	108
SVE 300/3N-30AM	B	30AM	254	42	Multiple Footprint 90 125 13 100 145 13			4	175	172.5	14	79	150	170	132
SVE 400/3N-30AM	B	30AM	274	52	Multiple Footprint 90 125 13 100 145 13			4	175	172.5	14	79	150	170	132
SVE 500/3N-40AM	C	40AM	330	78	Multiple Footprint 105 140 13 100 155 13			4	190	195.5	15	92	174	174	156.5
SVE 700/3N-40AM	C	40AM	330	78	Multiple Footprint 105 140 13 100 155 13			4	190	195.5	15	92	174	174	156.5
SVE 800/3N-51AM	D1	51AM	310	55	120	170-180	17	4	220	218.5	25	105	203	200	184
SVE 1200/3N-51AM	D1	51AM	310	55	120	170-180	17	4	220	218.5	25	105	203	200	184
SVE 1300/3N-51AM	D1	51AM	310	55	120	170-180	17	4	220	218.5	25	105	203	200	184

This information is furnished without warranty, representation, inducement or license of any kind. It is accurate to the best knowledge or is obtained from sources believed to be accurate. We therefore assume no legal responsibility.



SVE RANGE OVERVIEW

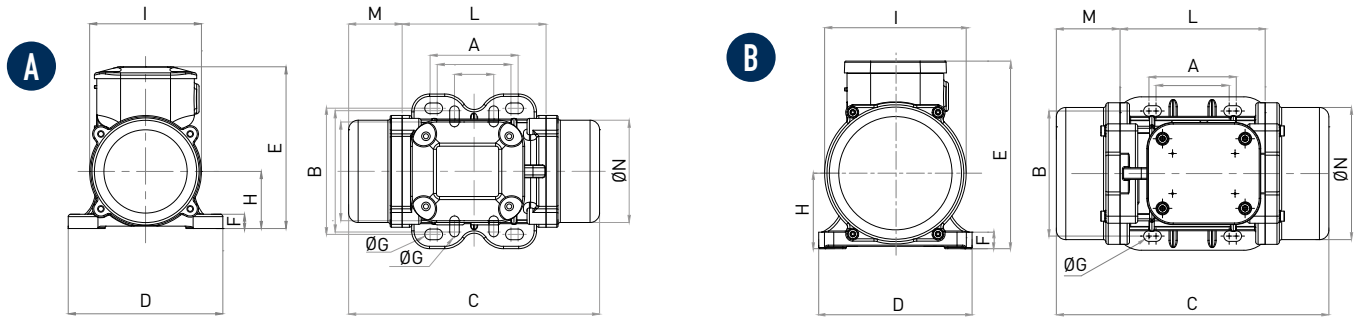

4 POLES - 1500/1800 rpm

Wm (Kgcm)	Model	Centrifugal Force (kg)	Weight (kg)	ELECTRICAL SPECIFICATIONS			
				Input Power (kW)	Nominal Current A max. (Y)	Ia/In	Cable Gland
50Hz	50 Hz	50Hz	50Hz	50Hz	50Hz (400V)	50Hz	Metric
2.0	SVE 40/15N-10AM	25	5	0.05	0.31	2.2	M16
6.0	SVE 90/15N-20AM	75	7	0.07	0.31	2.2	M20
15.4	SVE 200/15N-30AM	194	12	0.12	0.49	2.2	M20
33.4	SVE 400/15N-40AM	420	20	0.27	0.84	2.7	M20
40.1	SVE 500/15N-40AM	504	21	0.35	1.06	3.0	M20
26.6	SVE 300/15N-50AM	334	22	0.62	1.32	3.2	M20
26.6	SVE 300/15N-51AM	334	22	0.62	1.32	3.2	M20
56.8	SVE 700/15N-50AM	714	27	0.62	1.32	3.2	M20
56.8	SVE 710/15N-50AM	714	27	0.62	1.32	3.2	M20
75.6	SVE 950/15N-50AM	950	33	0.64	1.40	4.2	M20
88.7	SVE 1100/15N-50AM	1,114	36	0.64	1.40	4.0	M20
87.7	SVE 1100/15N-51AM	1,102	35	0.64	1.40	4.0	M20

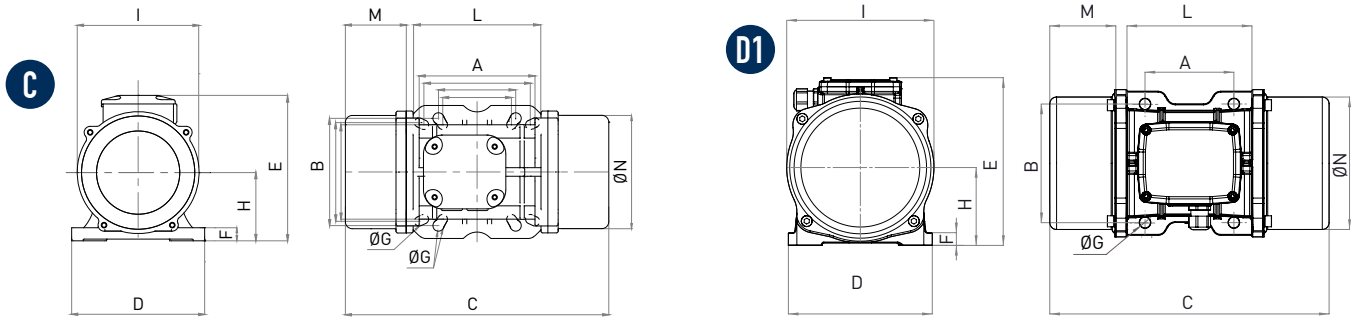

		DIMENSIONAL SPECIFICATIONS (mm)													
Model	Drawing	Size	C	M	A	B	ØG	Holes	D	E	F	H	I	L	N
50 Hz			50Hz	50Hz				n°							
SVE 40/15N-10AM	A	10A0	213	45	Multiple Footprint 62-74 106 9 33 83-102 7			4	130	135	11	50	96	107	85
SVE 90/15N-20AM	B	20A0	233	54	62-74	106	9	4	130	154	15	65	125	120	112
SVE 200/15N-30AM	C	30A0	274	52	Multiple Footprint 80 110 11 90 125 13 124 110 11 135 115 11			4	150	173	15	79	150	166	134
SVE 400/15N-40AM	D1	40A0	330	78	105	140	13	4	190	196	20	92	174	166	160
SVE 500/15N-40AM	D1	40A0	330	78	105	140	13	4	190	196	20	92	174	166	160
SVE 300/15N-50AM	D1	50A0	321	62	120	170	17	4	208	210	22	96	185	192	170
SVE 300/15N-51AM	D1	51A0	326	63	120	170	17	4	208	220	25	105	202	192	187
SVE 700/15N-50AM	D1	50A0	391	97	120	170	17	4	208	210	22	96	185	192	170
SVE 710/15N-50AM	D1	50A0	391	97	120	170	17	4	208	210	22	96	185	192	170
SVE 950/15N-50AM	D1	50A0	455	129	120	170	17	4	208	210	22	96	185	192	170
SVE 1100/15N-50AM	D1	50A0	455	129	120	170	17	4	208	210	22	96	185	192	170
SVE 1100/15N-51AM	D1	51A0	414	106	120	170	17	4	208	220	25	105	202	192	187

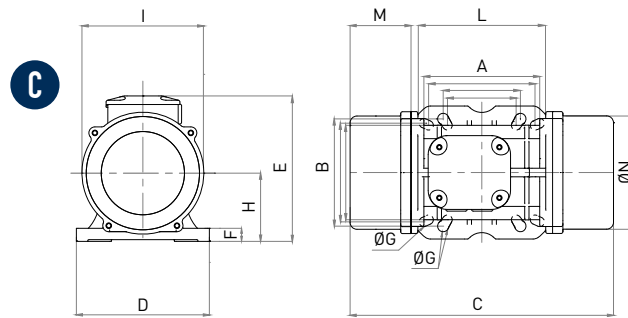

6 POLES - 1000/1200 rpm

Wm (Kgcm)	Model	Centrifugal Force (kg)	Weight (kg)	ELECTRICAL SPECIFICATIONS			
				Input Power (kW)	Nominal Current A max. (Y)	Ia/In	Cable Gland
50Hz	50Hz	50Hz	50Hz	50Hz	50Hz (400V)	50Hz	Metric
9.5	SVE 50/1N-30AM	53	10	0.12	0.30	2.2	M20
18.8	SVE 100/1N-30AM	105	11	0.12	0.30	2.2	M20
33.5	SVE 200/1N-40AM	187	19	0.15	0.65	2.2	M20
56.9	SVE 300/1N-50AM	318	26	0.25	0.67	2.7	M20
91.9	SVE 500/1N-50AM	513	34	0.55	1.22	3.0	M20
91.9	SVE 510/1N-50AM	513	34	0.55	1.20	3.0	M20

Notes:

.....

.....

.....

.....

.....

.....

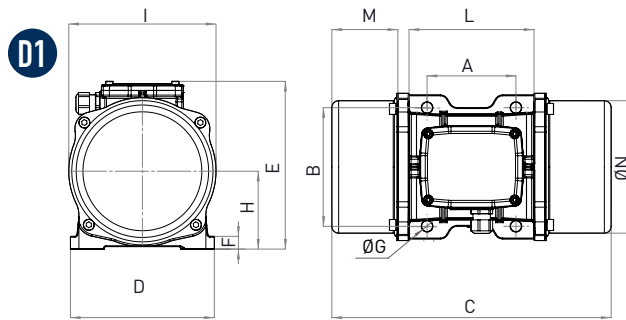

		DIMENSIONAL SPECIFICATIONS (mm)													
Model	Drawing	Size	C	M	A	B	ØG	Holes	D	E	F	H	I	L	N
50Hz			50Hz	n°											
SVE 50/1N-30AM	C	30A0	274	52	Multiple Footprint			4	150	173	15	79	150	166	134
					80	110	11								
					90	125	13								
					124	110	11								
SVE 100/1N-30AM	C	30A0	304	67	Multiple Footprint			4	150	173	15	79	150	166	134
					80	110	11								
					90	125	13								
					124	110	11								
SVE 200/1N-40AM	D1	40A0	330	78	105	140	13	4	170	196	20	92	174	166	160
SVE 300/1N-50AM	D1	50A0	391	97	120	170	17	4	208	210	22	96	185	192	170
SVE 500/1N-50AM	D1	50A0	455	129	120	170	17	4	208	210	22	96	185	192	170
SVE 510/1N-50AM	D1	50A0	455	129	120	170	17	4	208	210	22	96	185	192	170

Notes:

.....

.....

.....

.....

.....

.....

VISAM MOTOVIBRATORS

DESIGNED TO MEET YOUR NEEDS